

## Description

The MOC301X and MOC302X and MOC305X and MOC307X series combine an AlGaAs infrared emitting diode as the emitter which is optically coupled to a monolithic silicon random-phase photo triac in a plastic DIP6 package with different lead forming options.

With the robust coplanar double mold structure, MOC301X, MOC302X and MOC305X series provide the most stable isolation feature.

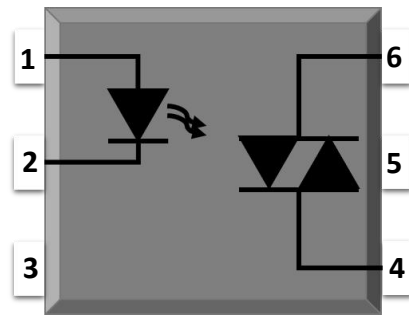
## Features

- High isolation 5000 VRMS
- DC input with random-phase photo triac output
- Operating temperature range - 40 °C to 100 °C
- REACH & RoHS compliance
- MSL class 1
- Regulatory Approvals
  - UL - UL1577
  - VDE - EN60747-5-5(VDE0884-5)
  - CQC - GB4943.1, GB8898
  - cUL- CSA Component Acceptance Service Notice No. 5A

## Applications

- Solenoid/valve controls
- Lighting controls
- Motor controls
- Temperature controls
- Static AC power switches
- Solid state relays
- Interfacing microprocessors to 115 to

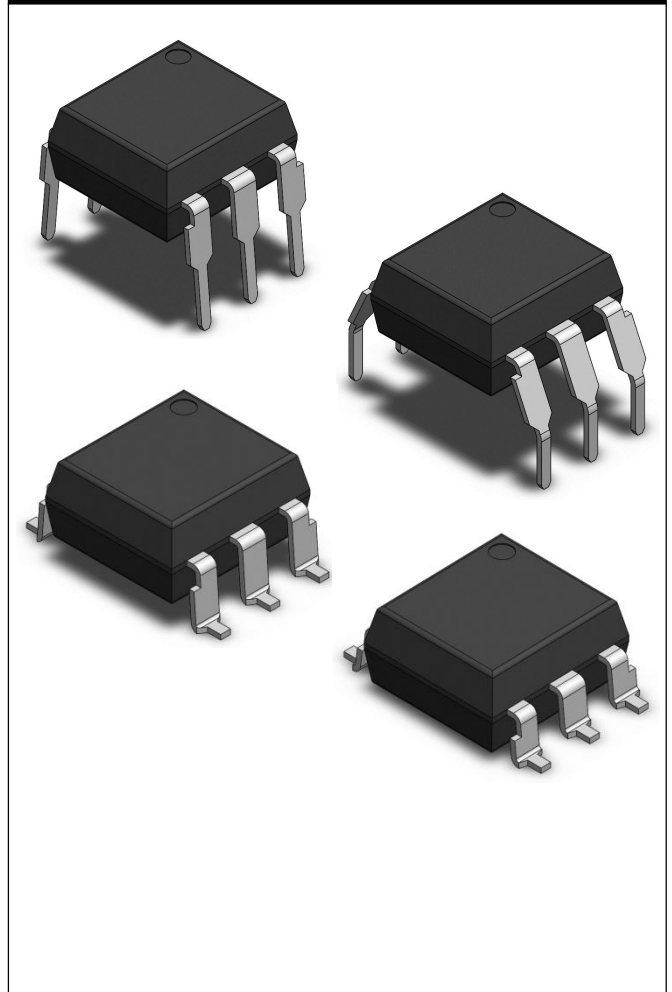
## SCHEMATIC

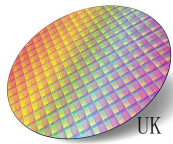


## PIN DEFINITION

- |            |              |
|------------|--------------|
| 1. Anode   | 4. Terminal  |
| 2. Cathode | 5. Substrate |
| 3. NC      | 6. Terminal  |

## PACKAGE OUTLINE



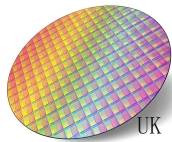


**ABSOLUTE MAXIMUM RATINGS**

PARAMETER	SYMBOL	VALUE	UNIT	NOTE
<b>INPUT</b>				
Forward Current	$I_F$	60	mA	
Reverse Voltage	$V_R$	6	V	
Junction Temperature	$T_j$	125	°C	
Input Power Dissipation	$P_I$	100	mW	
<b>OUTPUT</b>				
Off-state Output Terminal Voltage	MOC301X	250	V	
	MOC302X	400		
	MOC305X	600		
	MOC307X	800		
Peak Repetitive Surge Current PW=100μs, 120pps	$I_{TSM}$	1	A	
On-State RMS Current	$I_{T(RMS)}$	100	mA	
Junction Temperature	$T_j$	125	°C	
Output Power Dissipation	$P_O$	300	mW	
<b>COMMON</b>				
Total Power Dissipation	$P_{tot}$	400	mW	
Isolation Voltage	$V_{iso}$	5000	V <sub>rms</sub>	1
Operating Temperature	$T_{opr}$	-40~100	°C	
Storage Temperature	$T_{stg}$	-55~125	°C	
Soldering Temperature	$T_{sol}$	260	°C	2

Note 1. AC For 1 Minute, R.H. = 40 ~ 60%

Note 2. For 10 seconds

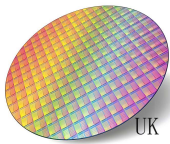


**ELECTRICAL OPTICAL CHARACTERISTICS at Ta=25°C**

PARAMETER	SYMBOL	MIN.	TYP.	MAX.	UNIT	TEST CONDITION	NOTE
INPUT							
Forward Voltage	V <sub>F</sub>	-	1.24	1.4	V	I <sub>F</sub> =10mA	
Reverse Current	I <sub>R</sub>	-	-	10	μA	V <sub>R</sub> =6V	
Input Capacitance	C <sub>in</sub>	-	8.5	250	pF	V=0, f=1kHz	
OUTPUT							
Peak Off-state Current, Either Direction	I <sub>DRM</sub>	-	-	100	nA	V <sub>DRM</sub> =Rated V <sub>DRM</sub> I <sub>F</sub> =0	3
Peak On-state Current, Either Direction	V <sub>TM</sub>	-	1.58	2.5	V	I <sub>TM</sub> =100mA	
Critical Rate of Rise of Off-state Voltage	dV/dt	1000	-	-	V/μs	V <sub>PEAK</sub> =Rated V <sub>DRM</sub>	4
TRANSFER CHARACTERISTICS							
LED Trigger Current	MOC3010,MOC3021, MOC3051,MOC3071	I <sub>FT</sub>	-	-	15	mA	Terminal Voltage = 3V I <sub>TM</sub> =100mA
	MOC3011,MOC3022, MOC3052,MOC3072		-	-	10		
	MOC3012,MOC3023, MOC3053,MOC3073		-	-	5		
Holding Current	I <sub>H</sub>	-	257	-	μA		
Isolation Resistance	R <sub>iso</sub>	10 <sup>12</sup>	10 <sup>14</sup>	-	Ω	DC500V, 40 ~ 60% R.H.	
Floating Capacitance	C <sub>IO</sub>	-	0.8	-	pF	V=0, f=1MHz	

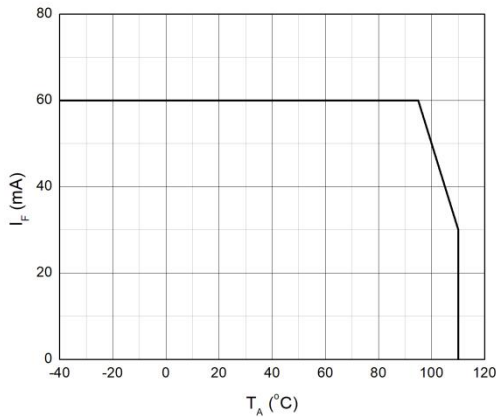
Note3. Test voltage must be applied within dV/dt rating.

Note4. Refer to Fig.15 & Fig.16

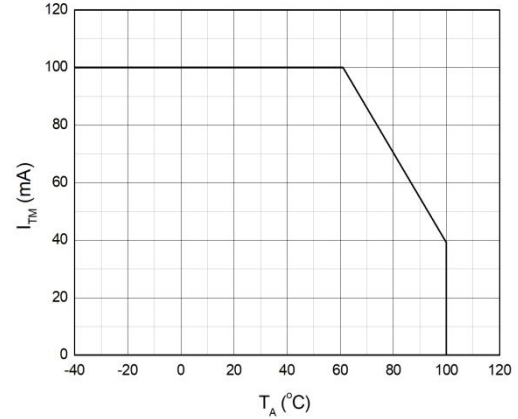


**CHARACTERISTIC CURVES**

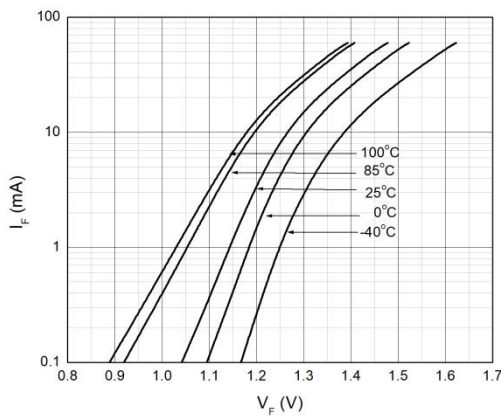
**Fig.1 Forward Current vs. Ambient Temperature**



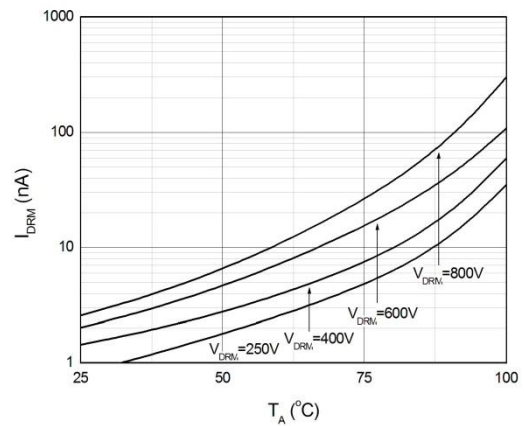
**Fig.2 On-state Terminal Current vs. Ambient Temperature**



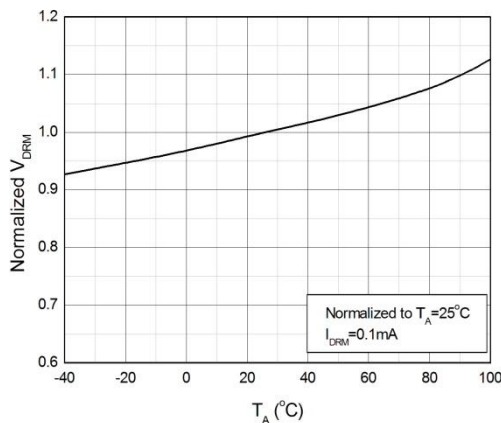
**Fig.3 Forward Current vs. Forward Voltage**



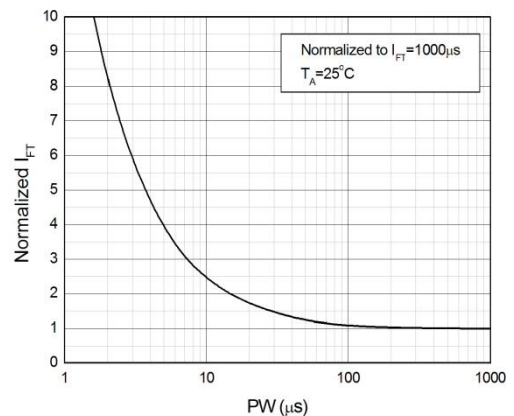
**Fig.4 Off-state Terminal Current vs. Ambient Temperature**

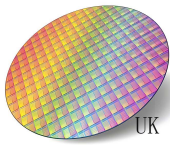


**Fig.5 Normalized Off-state Terminal Voltage vs. Ambient Temperature**



**Fig.6 Normalized Trigger Current vs. LED Trigger Pulse Width**





CHARACTERISTIC CURVES

Fig.7 Normalized Trigger Current vs. Ambient Temperature

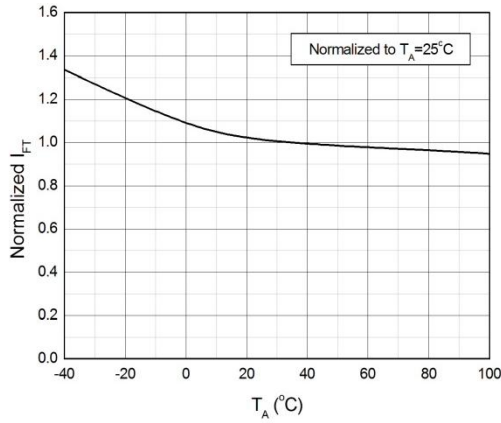


Fig.8 On-state Terminal Voltage vs. Ambient Temperature

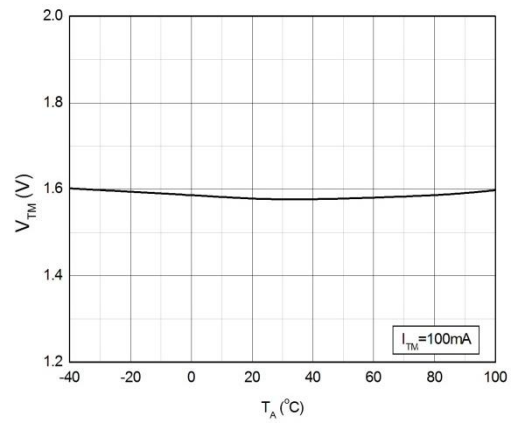


Fig.9 On-state Terminal Voltage vs. On-state Terminal Current

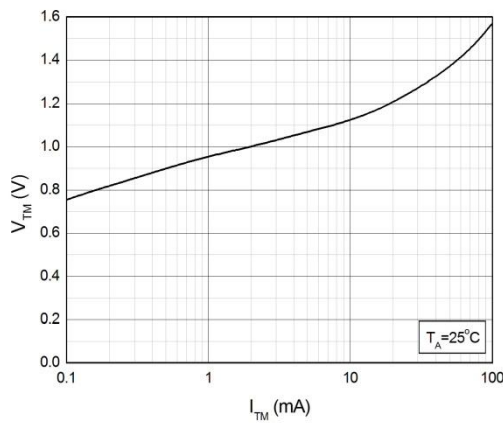


Fig.10 Holding Current vs. Ambient Temperature

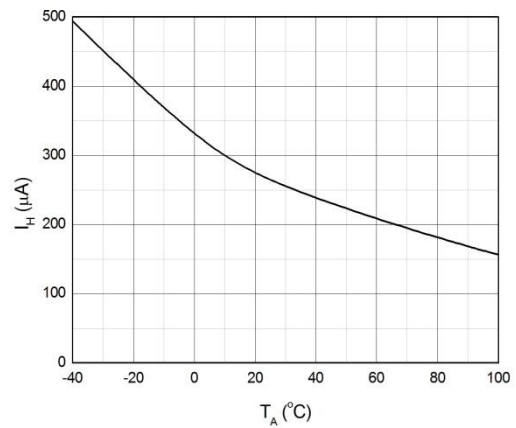


Fig.11 Turn On Time vs. Forward Current

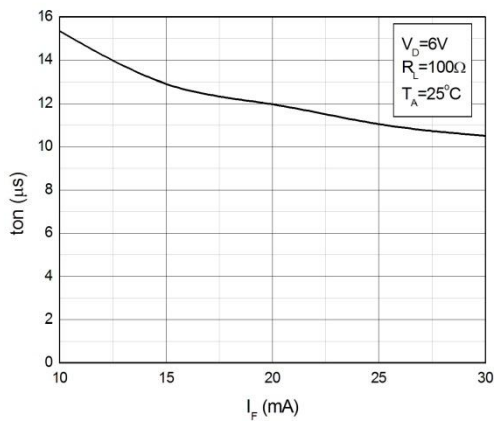
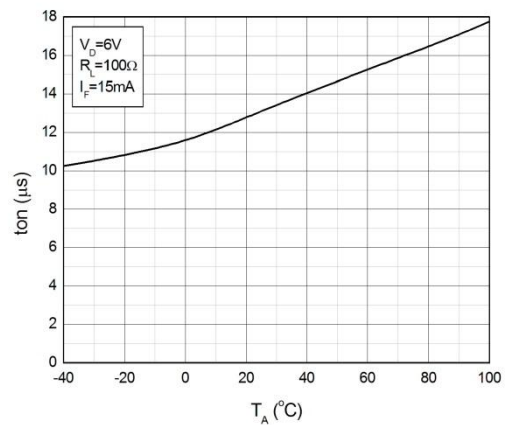
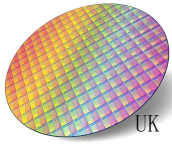


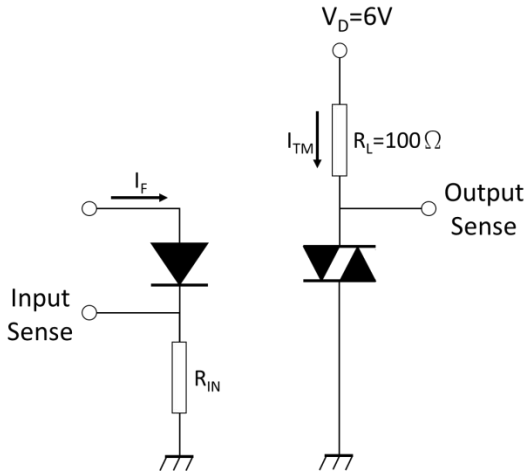
Fig.12 Turn On Time vs. Ambient Temperature



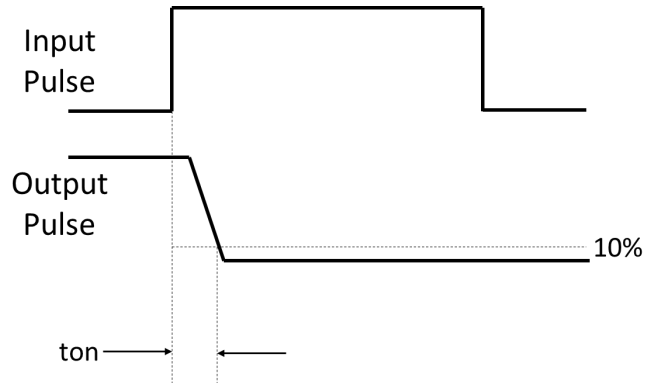


**TEST CIRCUITS**

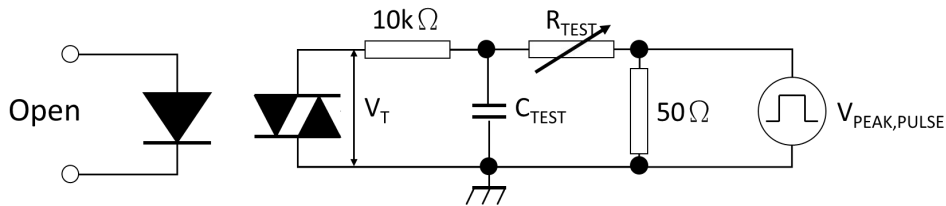
**Fig.13 Test Circuits of Turn On Time**



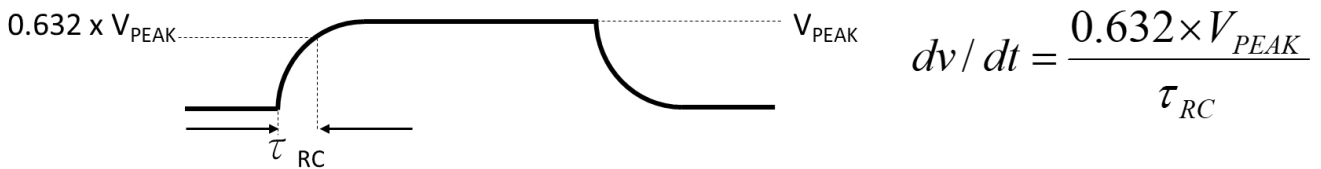
**Fig.14 Waveforms of Turn On Time**

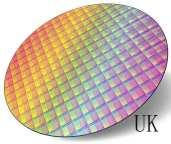


**Fig.15 Test Circuits of dV/dt**



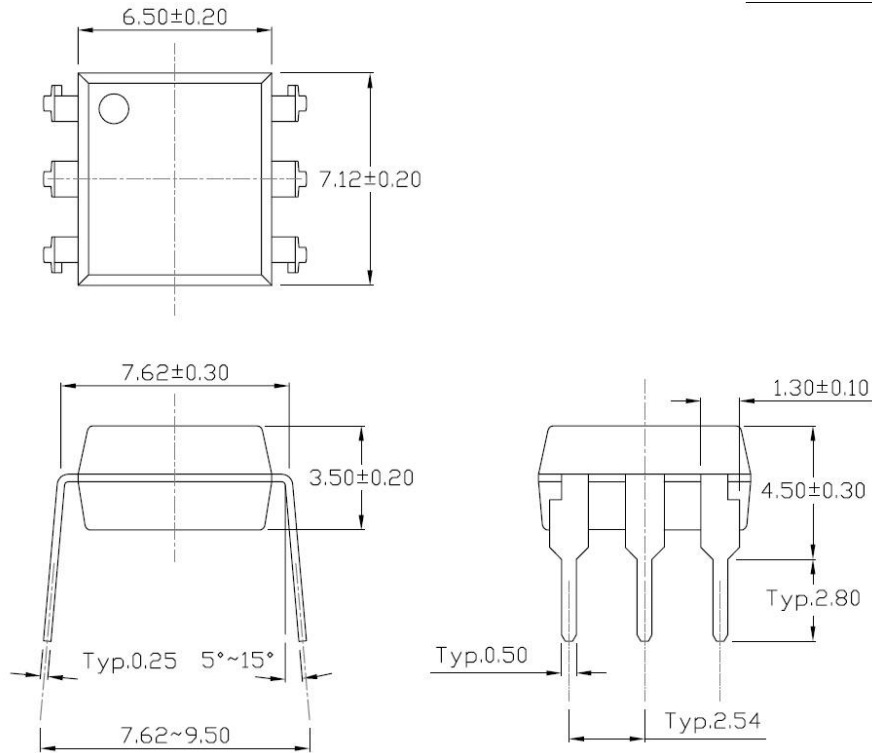
**Fig.16 Waveforms of dV/dt**



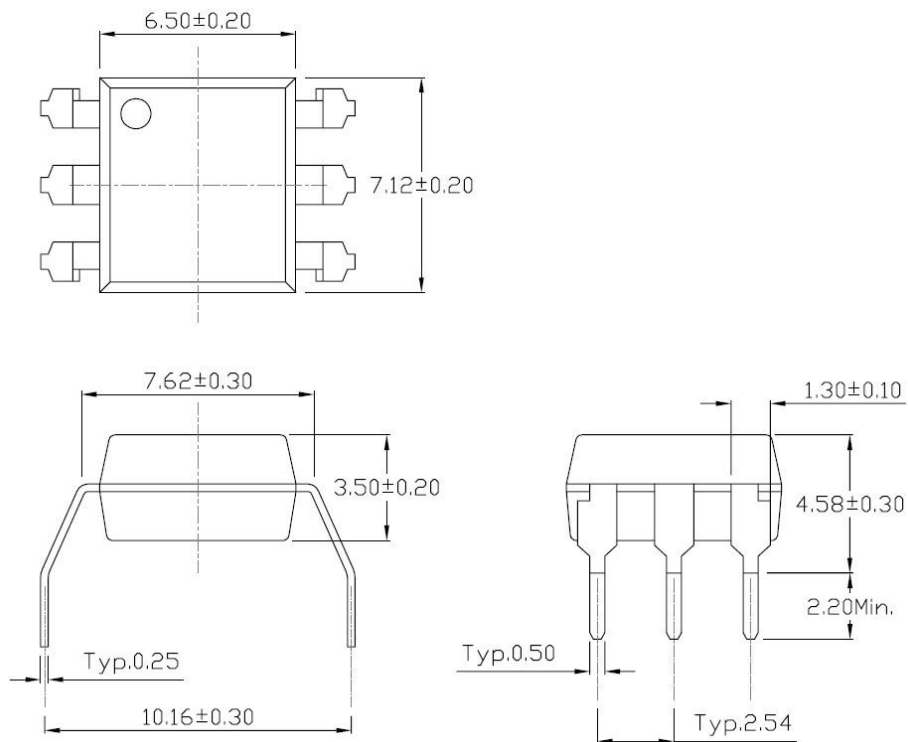


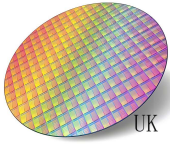
**PACKAGE DIMENSIONS (Dimensions in mm unless otherwise stated)**

**Standard DIP – Through Hole (DIP Type)**



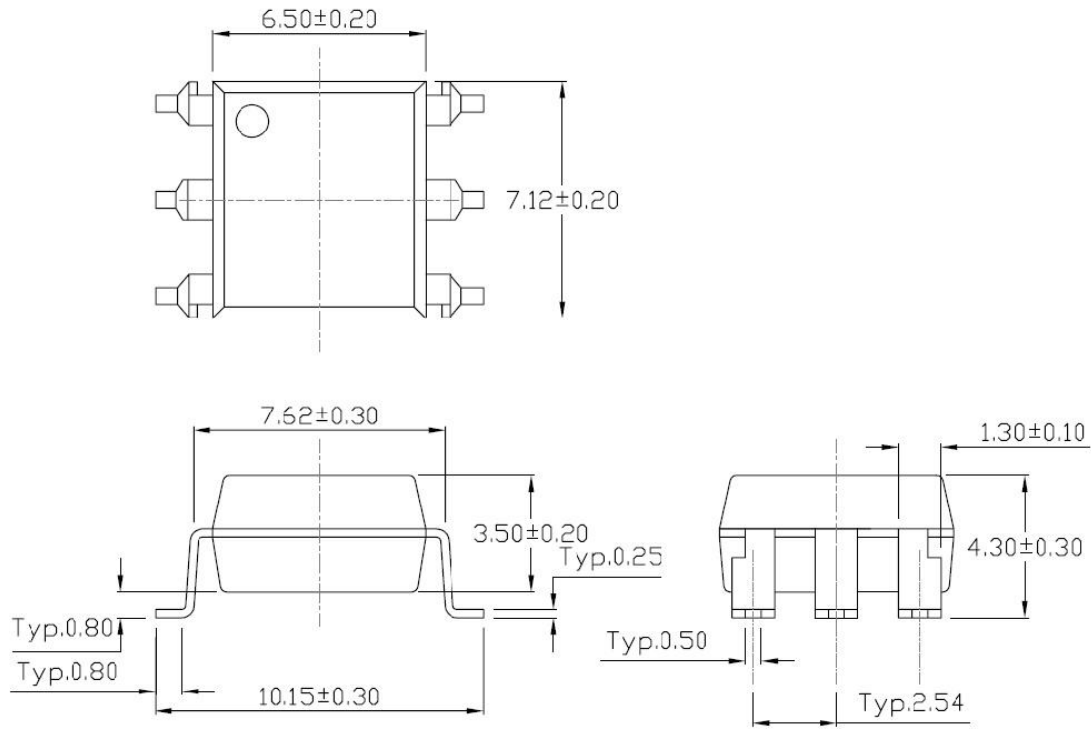
**Gullwing (400mil) Lead Forming – Through Hole (M Type)**



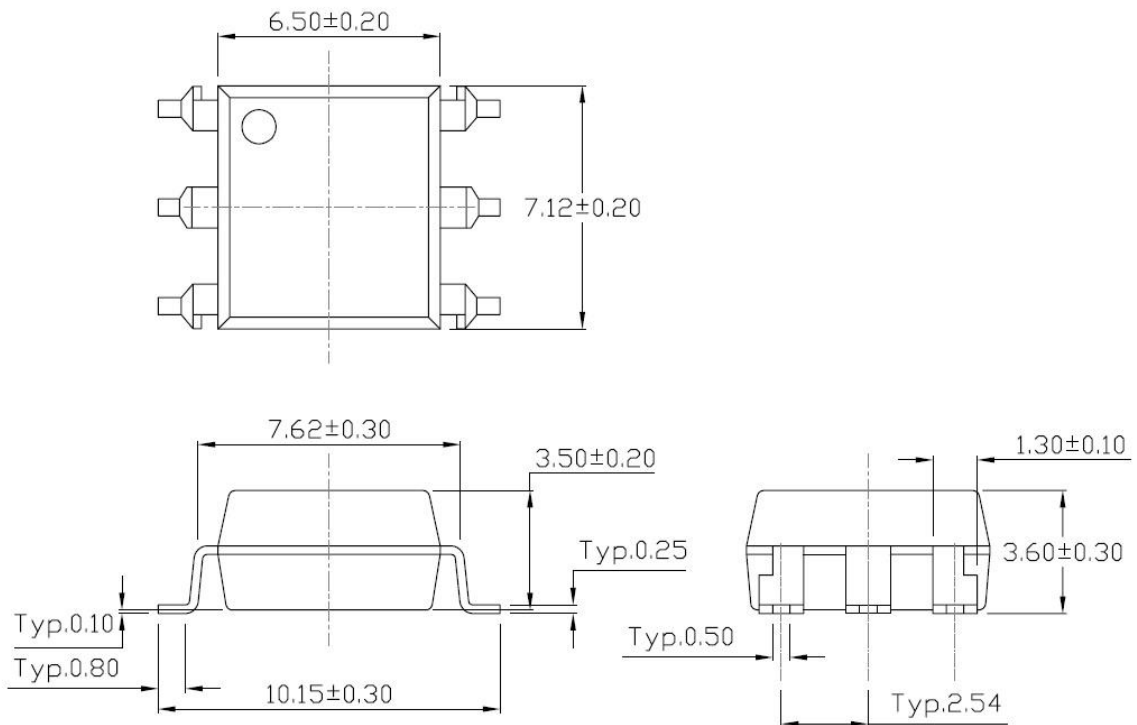


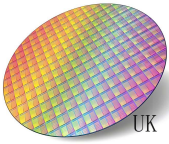
**PACKAGE DIMENSIONS (Dimensions in mm unless otherwise stated)**

**Surface Mount Lead Forming (S Type)**



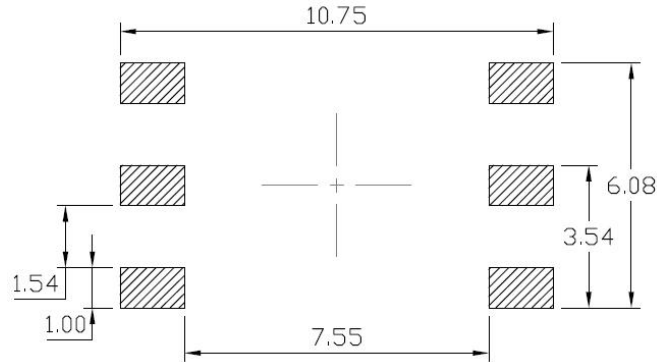
**Surface Mount (Low Profile) Lead Forming (SL Type)**



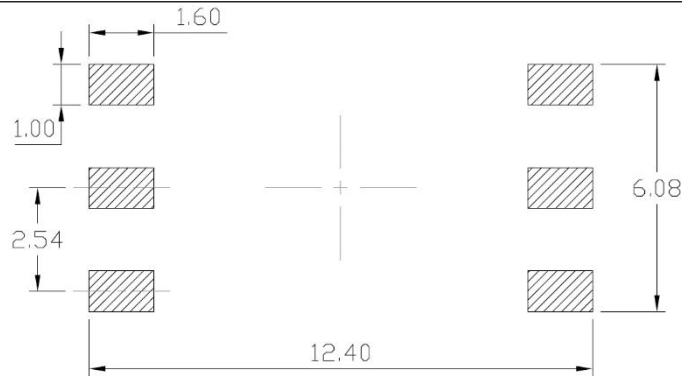


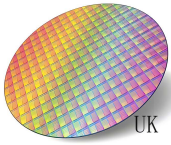
**RECOMMENDED SOLDER MASK (Dimensions in mm unless otherwise stated)**

**Surface Mount Lead Forming & Surface Mount (Low Profile) Lead Forming**



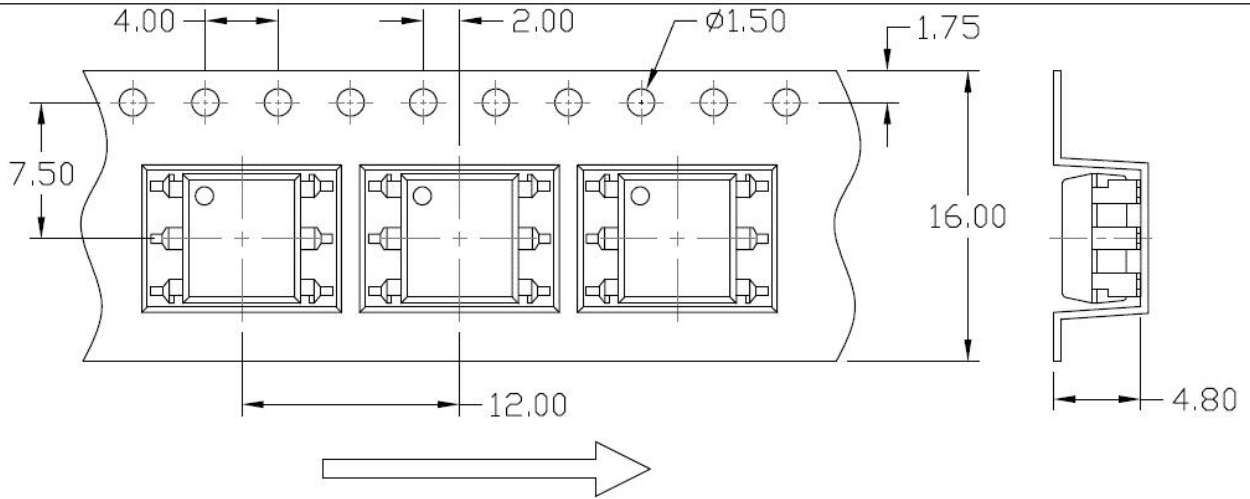
**Surface Mount (Gullwing) Lead Forming**



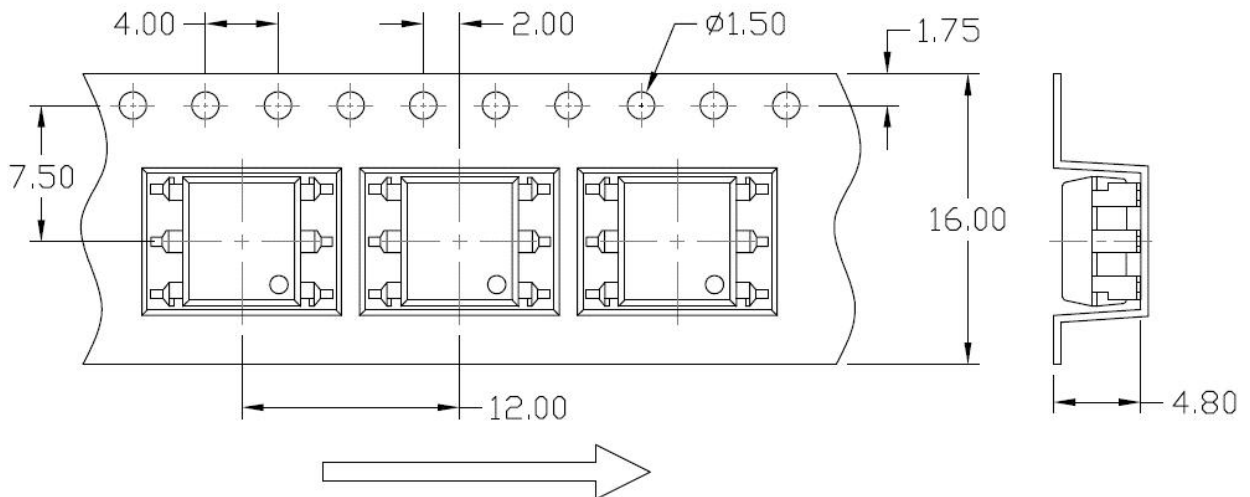


**CARRIER TAPE SPECIFICATIONS (Dimensions in mm unless otherwise stated)**

**Option SM(T&R) & SL(T1)**



**Option S(T2) & SL(T2)**



**ORDERING AND MARKING INFORMATION**

**MARKING INFORMATION**



**MOC30XX: Part Number & Rank**  
**I** : Company Abbr.  
**V** : VDE Option  
**Y** : Year Code  
**WW** : Work Week

**ORDERING INFORMATION**

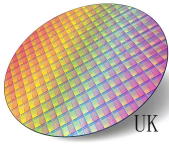
**LABEL INFORMATION**

**MOC30XX(V)(L)(Z)**

MOC30XX – Part Number  
 (10/11/12/21/22/23/51/52/53)  
 V – VDE Option (V or None)  
 L – Lead Form Option (M/SM/SL/None)  
 TR – Tape and Reel Option (T&R/T1/T2)

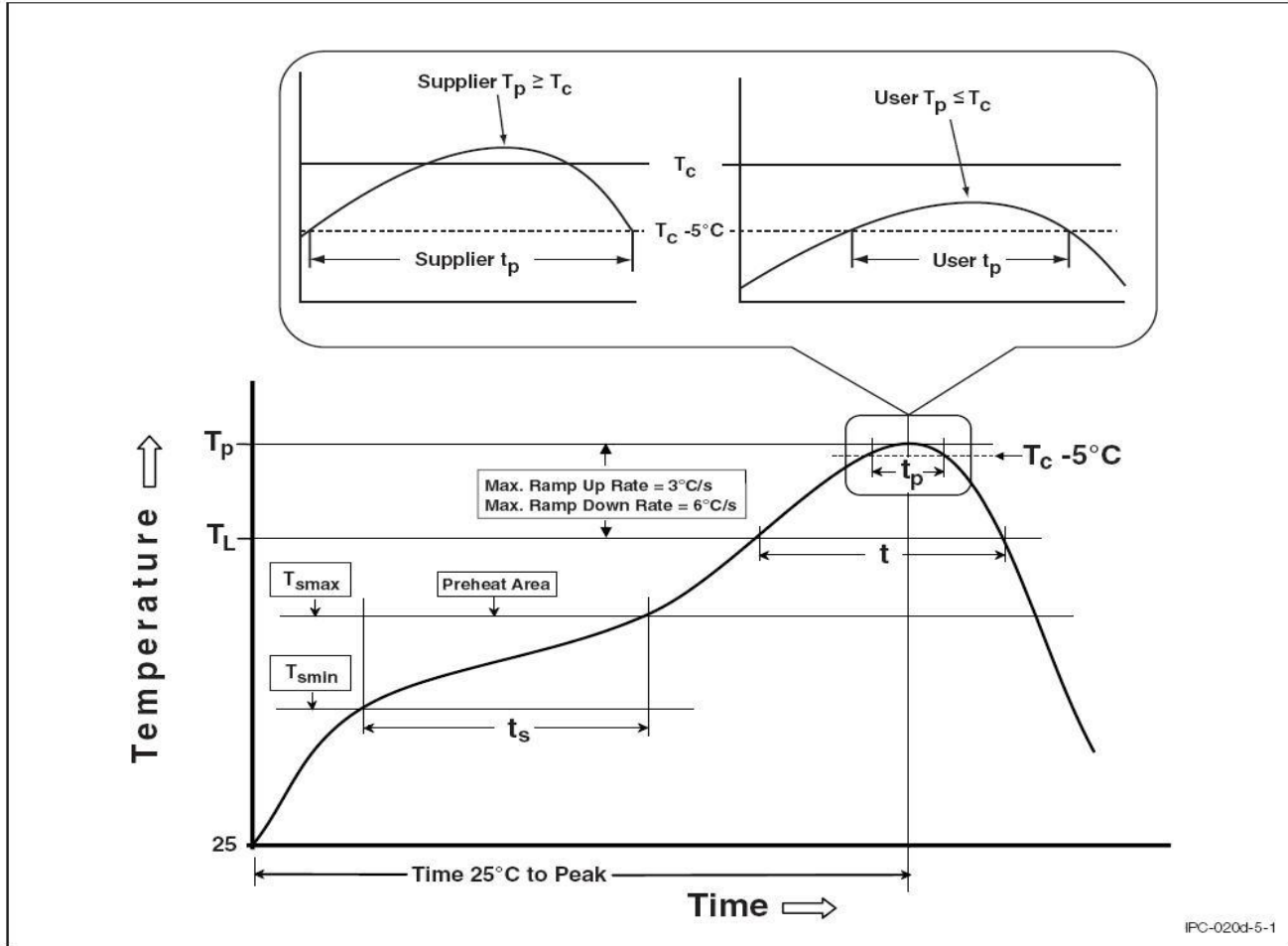
**Packing Quantity**

Option	Quantity	Quantity – Inner box	Quantity – Outer box
None	65 Units/Tube	16 Tubes/Inner box	10 Inner box/Outer box = 16k Units
M	65 Units/Tube	16 Tubes/Inner box	10 Inner box/Outer box = 16k Units
SM(T&R)	1000 Units/Reel	3 Reels/Inner box	5 Inner box/Outer box = 15k Units
SM(T1)	1000 Units/Reel	3 Reels/Inner box	5 Inner box/Outer box = 15k Units
SM(T2)	1000 Units/Reel	3 Reels/Inner box	5 Inner box/Outer box = 15k Units
SL(T2)	1000 Units/Reel	3 Reels/Inner box	5 Inner box/Outer box = 15k Units

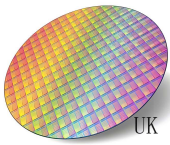


**REFLOW INFORMATION**

**REFLOW PROFILE**



Profile Feature	Sn-Pb Assembly Profile	Pb-Free Assembly Profile
Temperature Min. (TsmIn)	100	150°C
Temperature Max. (Tsmax)	150	200°C
Time (ts) from (TsmIn to Tsmax)	60-120 seconds	60-120 seconds
Ramp-up Rate (tL to tP)	3°C/second max.	3°C/second max.
Liquidous Temperature (TL)	183°C	217°C
Time (tL) Maintained Above (TL)	60 – 150 seconds	60 – 150 seconds
Peak Body Package Temperature	235°C +0°C / -5°C	260°C +0°C / -5°C
Time (tP) within 5°C of 260°C	20 seconds	30 seconds
Ramp-down Rate (TP to TL)	6°C/second max	6°C/second max
Time 25°C to Peak Temperature	6 minutes max.	8 minutes max.



## DISCLAIMER

- ASG is continually improving the quality, reliability, function and design. ASG reserves the right to make changes without further notices.
- The characteristic curves shown in this datasheet are representing typical performance which are not guaranteed.
- ASG makes no warranty, representation or guarantee regarding the suitability of the products for any particular purpose or the continuing production of any product. To the maximum extent permitted by applicable law, ASG disclaims (a) any and all liability arising out of the application or use of any product, (b) any and all liability, including without limitation special, consequential or incidental damages, and (c) any and all implied warranties, including warranties of fitness for particular
- The products shown in this publication are designed for the general use in electronic applications such as office automation, equipment, communications devices, audio/visual equipment, electrical application and instrumentation purpose, non-infringement and merchantability.
- This product is not intended to be used for military, aircraft, automotive, medical, life sustaining or lifesaving applications or any other application which can result in human injury or death.
- Please contact ASG sales agent for special application request.
- Immerge unit's body in solder paste is not recommended.
- Parameters provided in datasheets may vary in different applications and performance may vary over time. All operating parameters, including typical parameters, must be validated in each customer application by the customer's technical experts. Product specifications do not expand or otherwise modify ASG's terms and conditions of purchase, including but not limited to the warranty expressed therein.
- Discoloration might be occurred on the package surface after soldering, reflow or long-time use. It neither impacts the performance nor reliability.